

ULC Installation Information

All Installations:

- Transformer - Plug-in type or hardwired, minimum rated 16Vac, 37-40VA Class 2 Power limited, CSA/ETL/cUL Listed
- Install with ULC Listed devices where applicable

Requirements	Household Burglary	Household Fire	Central Station Burglary Monitoring	Central Station Fire Monitoring	Local Burglary
Minimum battery standby	4 Hour	24 Hour	24 Hour	24 Hour	24 Hour
Battery size <i>Note: battery capacity can be selected based on calculated AUX current consumption for the system (including all accessories)</i>	12V/4Ah	1 x 12V/7Ah or 2 x 12V/7Ah	1 x 12V/7Ah or 2 x 12V/7Ah	1 x 12V/7Ah or 2 x 12V/7Ah	1 x 12V/7Ah or 2 x 12V/7Ah
System Entry delay	≤ 45 Sec.	not applicable	programmable	not applicable	≤ 60 Sec.
System Exit delay	≤ 60 Sec.	not applicable	programmable	not applicable	≤ 120 Sec.
Minimum Bell cutoff time	4 minutes	5 minutes	programmable	not applicable	programmable
Equipment Standard	ORD-C1023-1974	CAN/ULC-S545-02	CAN/ULC-S304-06	CAN/ULC-S559-04	CAN/ULC-S303
Installation Standard	CAN-ULC-S310	CAN/ULC-S540	CAN/ULC-S302	CAN/ULC-S561-03	CAN/ULC-S302
Communicator	Enabled	Enabled	Enabled <i>*see Note 1</i>	Enabled <i>*see Note 2</i>	Optional
ULC Marking <i>Note: for residential installation the commercial type marking is also acceptable (Subscribers' Unit)</i>	Household Burglary Alarm System Control Unit	Household Fire Warning Alarm System Control Unit	Subscribers' Unit Burglary or Subscribers' Unit-Accessory Burglary	Subscribers' Unit Fire Alarm or Subscribers' Unit-Accessory Fire Alarm	Local Burglar Alarm
Power LED (Model ULC-LA) (Not required if PK/RFK55XX keypads with AC indicator enabled are being used)	Optional	Required	Required	Required	Required
AC power	Plug-in transformer Optional hardwired connection	Plug-in transformer Optional hardwired connection	Plug-in transformer Optional hardwired connection	Hardwired connection required Check Local Authority	Plug-in transformer Optional hardwired connection
Tamper protection	Optional	Optional	Required <i>*see Note 8</i>	Optional	Required <i>*see Note 8</i>
Cabinet <i>Note: ULC marking might be applied on the outside of the enclosure or inside on the PCB assembly</i>	DSC Models PC5003C PC500C Concourse	DSC Models PC5003C PC4050C Concourse	DSC Models PC5003C PC4050C	DSC Models PC5003C PC4050C PC4050CR (Red)	DSC Models (Attack Resistant) CMC-1 PC4050CAR
Special Notes	-----	<i>*see Note 4</i>	<i>*see Note 5</i>	<i>*see Notes 3 & 7</i>	<i>*see Notes 5 & 6</i>

*Notes:

1. Line Security (applicable to Commercial Burglary/Financial Installations)

Passive Levels <i>Note: Test Transmission required every 24h (on each communication channel)</i>	Transmitter(s) Equipment at protected premises	Supervision of communication channel(s)	Receiver Equipment at Signal Receiving Centre (SRC)	Risk Levels
P1	One communication channel: Dialer (PC4020/PC1864/1832/1616) GSM (GS3055/3060) IP (T-Link TL250/TL300)	Loss of communication channel shall initiate local trouble signal within 180 Sec.	SG-MLR2-DG SG-MLR2000 SG-System III SG-System II	Low
P2	Two communication channels: Dialer and GSM back-up Dialer and IP back-up Refer to diagrams 3, 6 or 7.	Failure of either channel shall be reported to the SRC within 240 Sec.	SG-MLR2-DG SG-MLR2000 SG-System III SG-System II	Medium
P3	Dual Communication System: GSM and IP Dialer and IP Dialer and GSM Status change signals shall be sent simultaneously over both communication channels. Refer to diagrams 3, 6 or 7. Use separate PGM outputs programmed to activate for each type of event identified as a status change signal: Burglar Alarm, Holdup, Duress, Tamper, Opening/Closing. Use PC5108 where more zone inputs are required to accommodate the transmission of these signals.	Failure of either channel shall be reported to the SRC within 240 Sec.	SG-MLR2-DG SG-MLR2000 SG-System III SG-System II	High

Note: The telephone service should be of a type that provides for timed release disconnect, in order to give the digital alarm communicator transmitter (dialer) the ability to disconnect an incoming call to the protected premises.



29002157R009

Active Levels <i>Note: Check-in/Polling signal required every 90 Sec.</i>	Transmitter(s) Equipment at protected premises	Supervision of communication channel(s)	Receiver Equipment at Signal Receiving Centre (SRC)	Risk Levels	Back-up requirements for network equipment
A1	IP (T-Link TL250/TL300) with AES 128bit encryption Refer to diagrams 2, 4 or 5	Loss of communication channel shall be indicated at SRC within 180 Sec.	SG-System III SG-System II (512 supervised transmitters)	Low	24h standby power or dialer as back-up
A2	IP (T-Link TL250/TL300) with AES 128bit encryption Refer to diagrams 2, 4 or 5	Loss in 180 Sec. at SRC; Identification at SRC; Compromise detection 240 Sec.	SG-System III SG-System II (512 supervised transmitters)	Medium	24h standby power or dialer as back-up
A3	IP (T-Link TL250/TL300) with AES 128bit encryption Refer to diagrams 2, 4 or 5	Loss in 180 Sec. at SRC; Identification at SRC; Compromise detection 180 Sec. (substitution)	SG-System III SG-System II (512 supervised transmitters)	High / Financial and High Value Asset	24h standby power or GSM as back-up
A4	IP (T-Link TL250/TL300) with AES 128bit encryption Refer to diagrams 2, 4 or 5	Loss in 180 Sec. at SRC; Identification at SRC; Compromise detection 180 Sec. (substitution) Compromise Signal	SG-System III SG-System II (512 supervised transmitters)	Very High	24h standby power

Note: For equipment used at the protected premises or SRC and intended to facilitate IP communications (hubs, routers, NID, DSL/Cable modems) 24h back-up power is required. Where such cannot be facilitated, a secondary (back-up) communication channel is required.

Notes for using Private, Corporate and High Speed Data Networks: Network access and domain access policies shall be set to restrict unauthorized network access, and "spoofing" or "denial of service" attacks. Select the internet service providers that have redundant servers/systems, back-up power, routers with firewalls enabled and methods to identify and protect against "denial of service" attacks (i.e. via "spoofing").

Notes for using Public Switched and Wireless Data Networks: Communication channels shall be facilitated such that the communicator will restrict unauthorized access, which could otherwise compromise security.

2. Fire Monitoring Communication Systems (Refer to the wiring diagrams in this guide for possible configurations)

Fire alarms shall be received at SRC in 60 Sec.

Trouble signals shall be received at SRC in 90 Sec.

Type	Transmitter(s) Equipment at protected premises	Supervision of communication channel(s)	Receiver Equipment at Signal Receiving Centre (SRC)
Passive <i>Note: Test Transmission required every 24h (on each communication channel).</i>	Dual Communication System: Dual Dialer (PC4701/PC5700) Note: Subject to AHJ approval Dialer with GSM Dialer with IP Fire Alarms shall be sent simultaneously over both communication channels	Failure of either channel shall be reported to the SRC within 180 Sec. Failure of both channels shall be indicated locally in 240 Sec.	SG-MLR2-DG SG-MLR2000 SG-System III SG-System II
Active <i>Note: Check-in/Polling signal required every 90 Sec.</i>	IP (T-Link TL250/TL300) optional AES 128bit encryption	Loss of communication channel shall be indicated at SRC within 180 Sec.	SG-System III SG-System II (512 supervised transmitters)

Note: Models SG-MLR2-DG, SG-MLR2000 are not ULC Listed under the ULC-S559-04 requirements.

- Each ULC labelled "Subscribers' Unit Fire and/or Burglary" communication system shall be connected to a ULC labelled "Fire Alarm Control Unit" if they are to monitor a complete fire alarm system. System fire alarms, supervisory and troubles signals shall be transmitted to the SRC.
- Program input zones as Fire Type for connection of ULC labelled 4-wire smoke detectors (e.g. DSC FSA-410A series) or program PGM 2 for connection of compatible ULC labelled 2-wire smoke detectors (e.g. DSC FSA-210A series). Refer to Zone Wiring Diagrams in this guide.
- Double end of line zone configuration must be used for Medium, High and Very High Risk Installations (refer to Zone Wiring Diagrams in this guide for possible configurations).
- Only one contact per zone (refer to Zone Wiring Diagrams for double door/window contact in this guide).
- This may be connected to ULC labelled Sprinkler Riser devices (refer to Zone Wiring Diagrams in this guide).
- All system enclosures must be 24h tamper protected against opening or removal (DSC Tamper Kit T-1 or equivalent). This includes control unit and accessory cabinets, transmitters, initiating devices and bells/strobes. Keypads must be tampered if they use a zone input or if they are installed outside the protected area.

Programming

The notes in the installation and programming sections describing the system configurations for ULC Listed installations must be implemented.

Protection of the Control Unit - Burglary

The local control unit and local power supply must be protected in one of the following ways:

- The control unit and power supply must be located within the area of greatest protection on a tamper protected circuit
- Each partition shall arm the area protecting the control unit and the audible alarm device power supply. This may require duplicate protection armed by each partition. Access to this protected area, without causing an alarm, will require that all partitions are disarmed

In all cases described above, the protected area for the control unit must be programmed so that it cannot be bypassed, and installed in accordance with CAN/ULC-S302 or CAN/ULC-S310.

User Information

The installer should advise the users and note the following in the user instruction manual:

- Service organization name and telephone number
- The programmed exit time
- The programmed entry time

Zone Wiring Diagrams

4-Wire Smoke Detectors

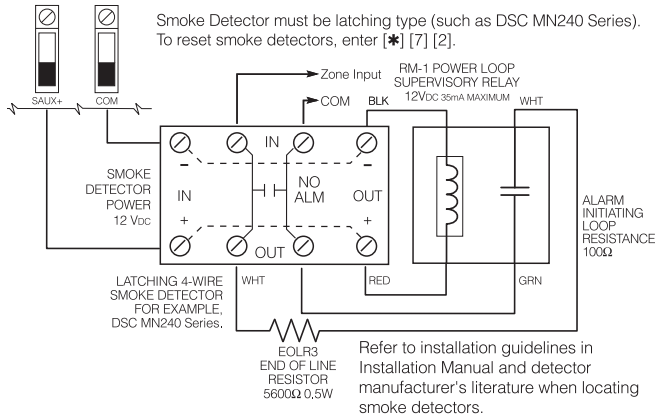

Double End-of-line Zone Configuration

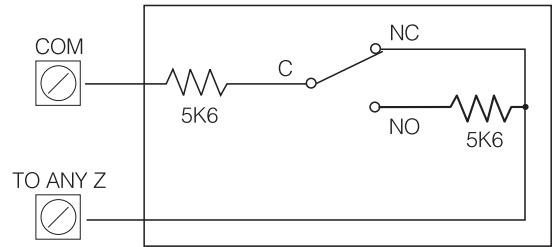

Door/Window Contact (1)
ULC Commercial Zone
 For One Form C Contact

2-Wire Smoke Detectors

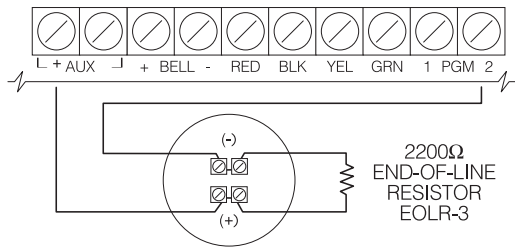

Double End-of-line Zone Configuration

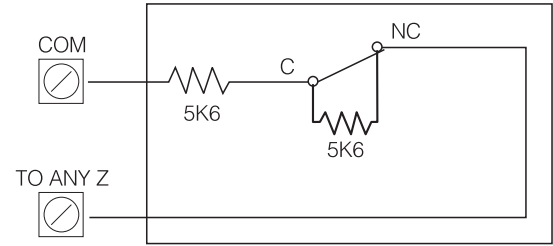

Door/Window Contact (2)
ULC Commercial Zone
 For One Form A Contact

Water Flow Connection

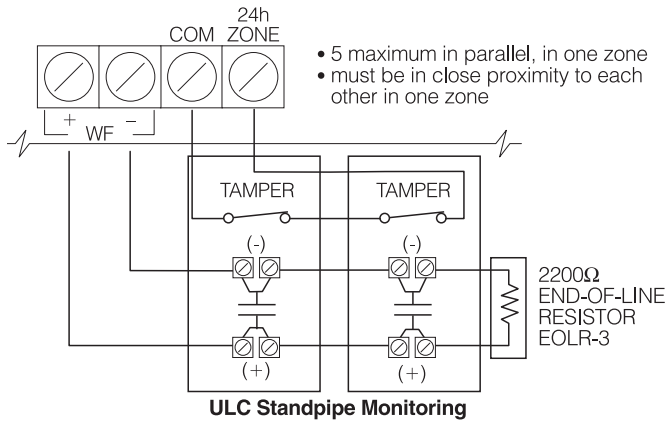

Double End-of-line Zone Configuration

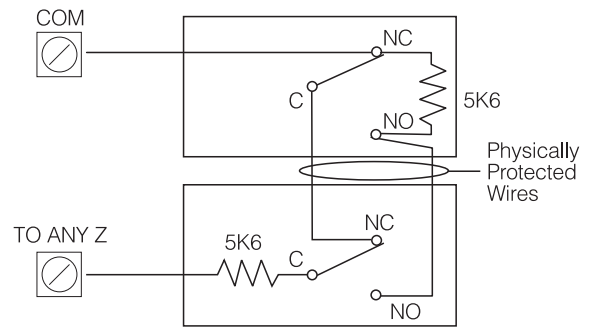

Double Door/Window
ULC Commercial Zone
 Uses Two Form C Contacts

Double End-of-line Zone Configuration

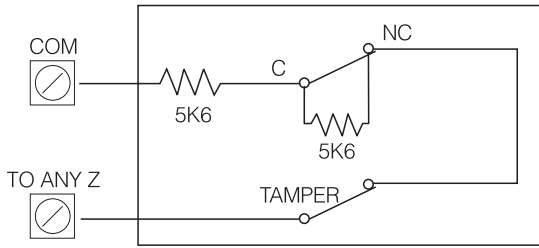

**Intrusion Detector (with tamper)
ULC Commercial Zone**
For One Form A Contact

Double End-of-line Zone Configuration

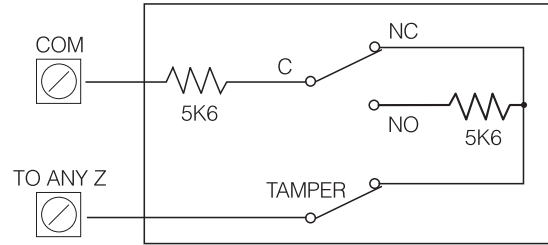

**Intrusion Detector
ULC Commercial Zone**
For One Form C Contact

Double End-of-line Zone Configuration

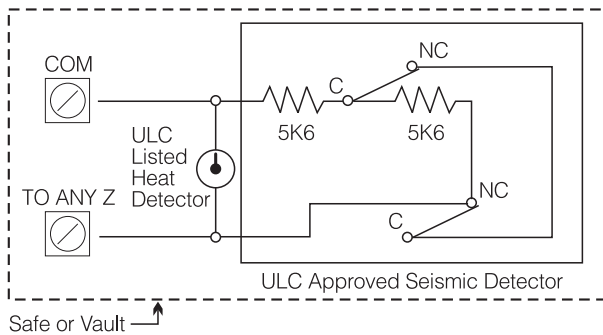

ULC Safe and Vault Installation
For Heat and Seismic Detector

NOTE:

The tampers and relays contacts (NC) used in door/window detectors or motion detectors are shown as the product is powered-up and in normal supervisory condition.



Fire Monitoring Communication Systems Wiring Diagrams

1. DSC Subscribers' Unit Fire and Dual Dialer (Passive Communication System)

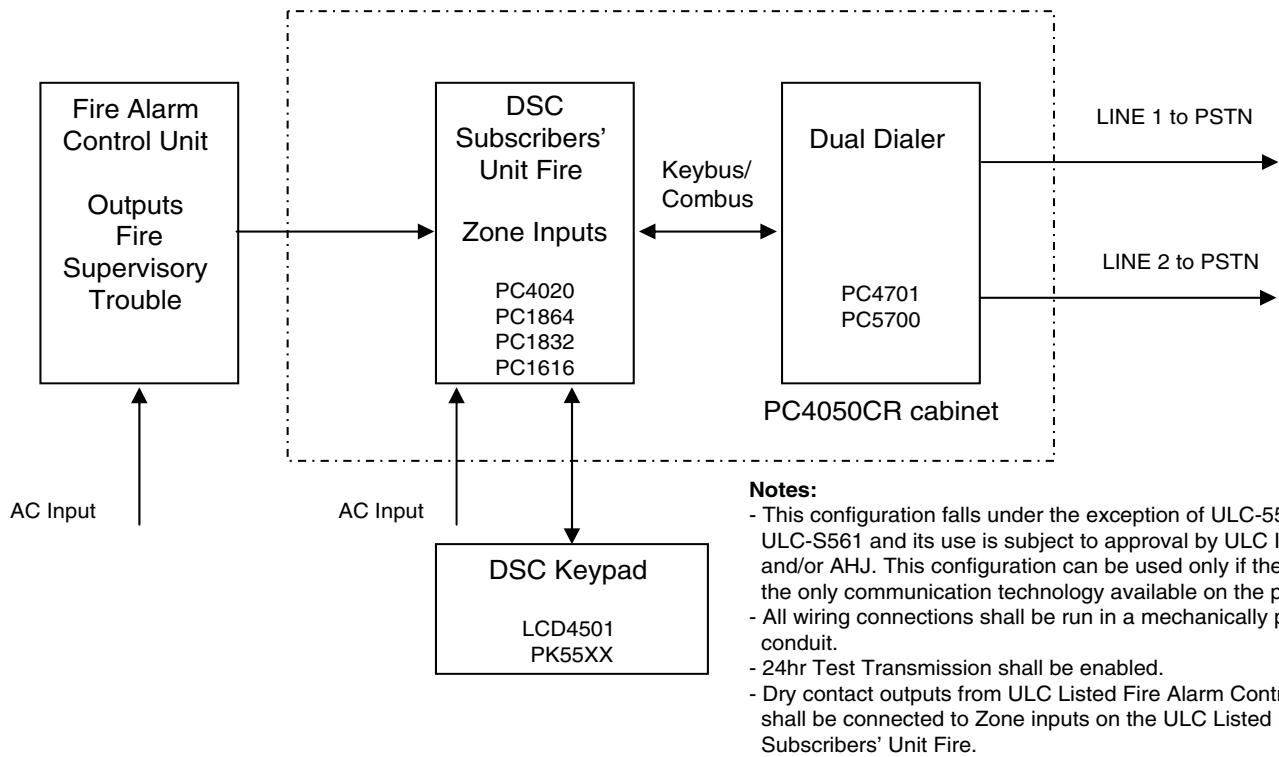

2. DSC Subscribers' Unit Fire and IP Transmitter (Active Communication System)

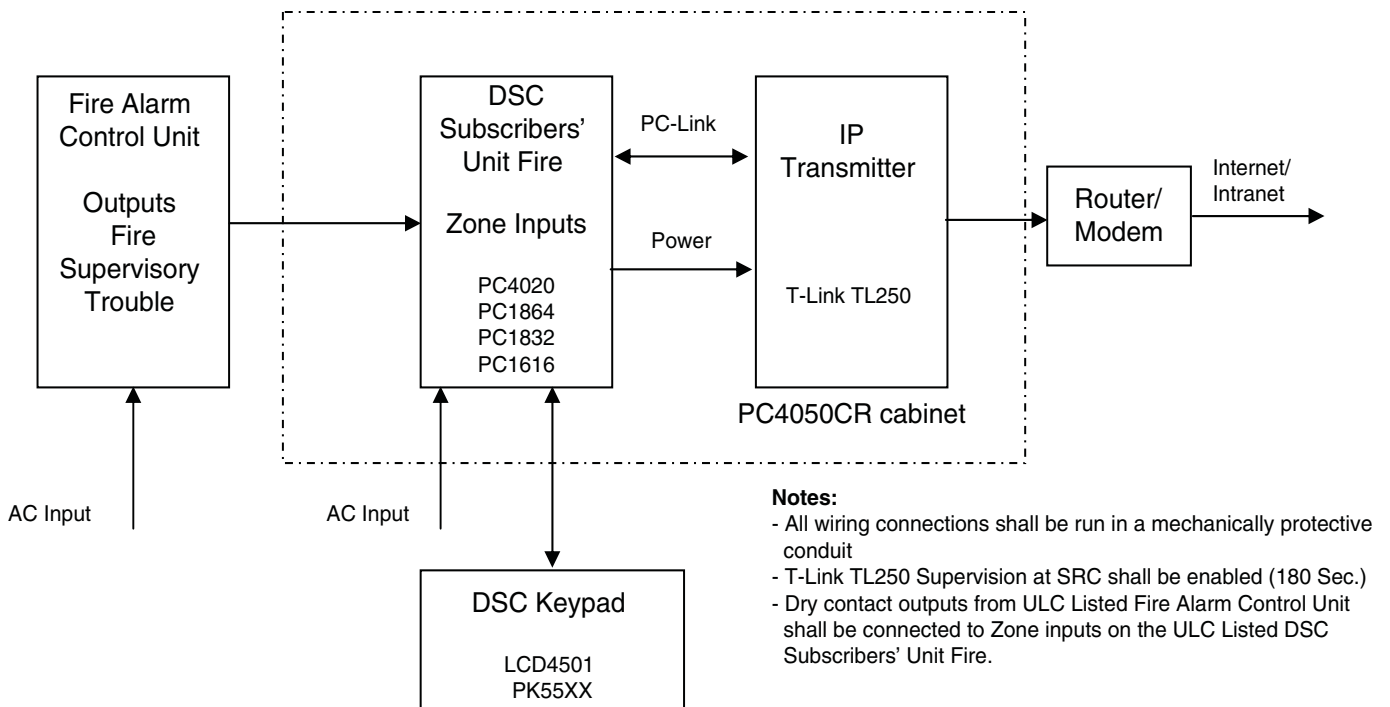

3. DSC Subscribers' Unit Fire and IP Transmitter (Passive Communication System)

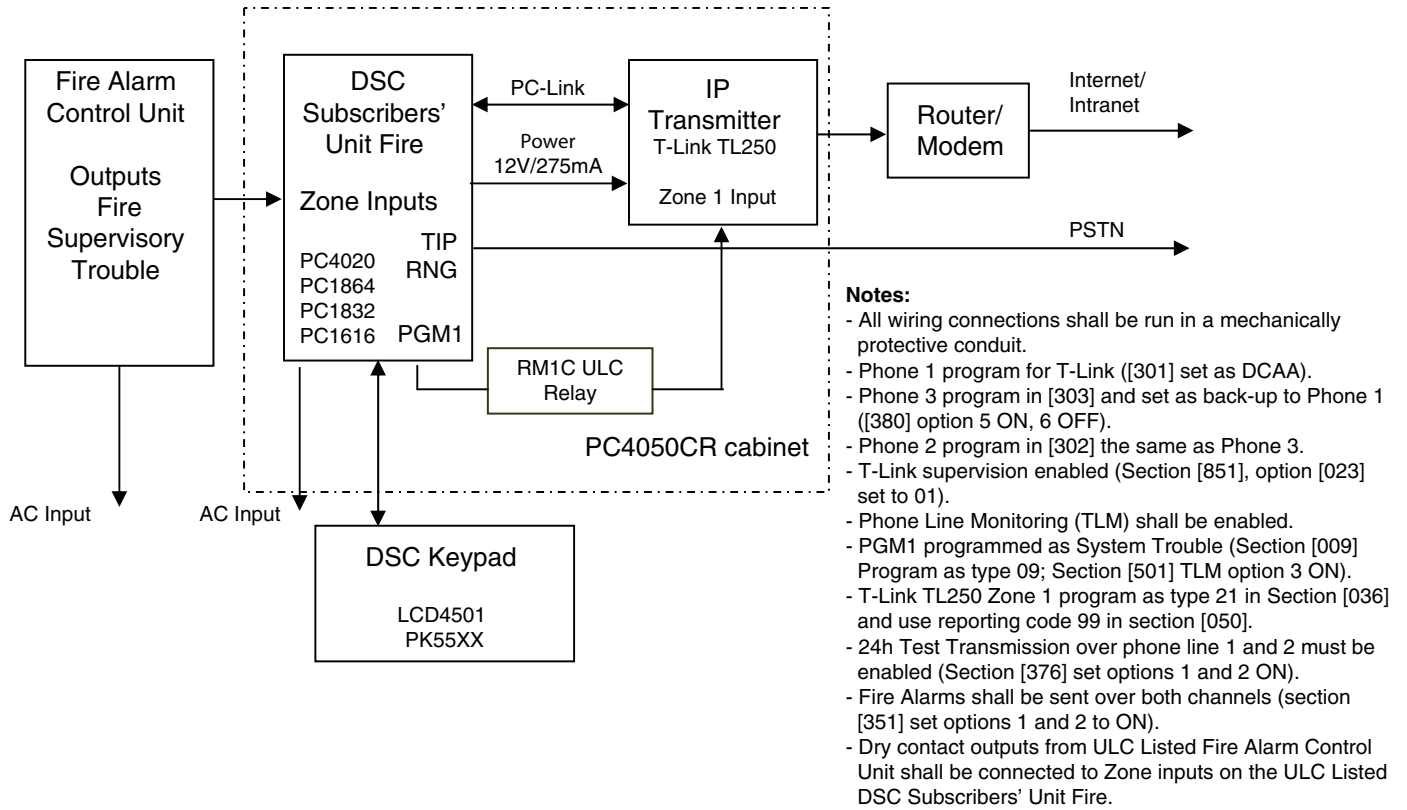

4. Fire Alarm Control Unit (with no dialer) and IP Transmitter (Active Communication System)

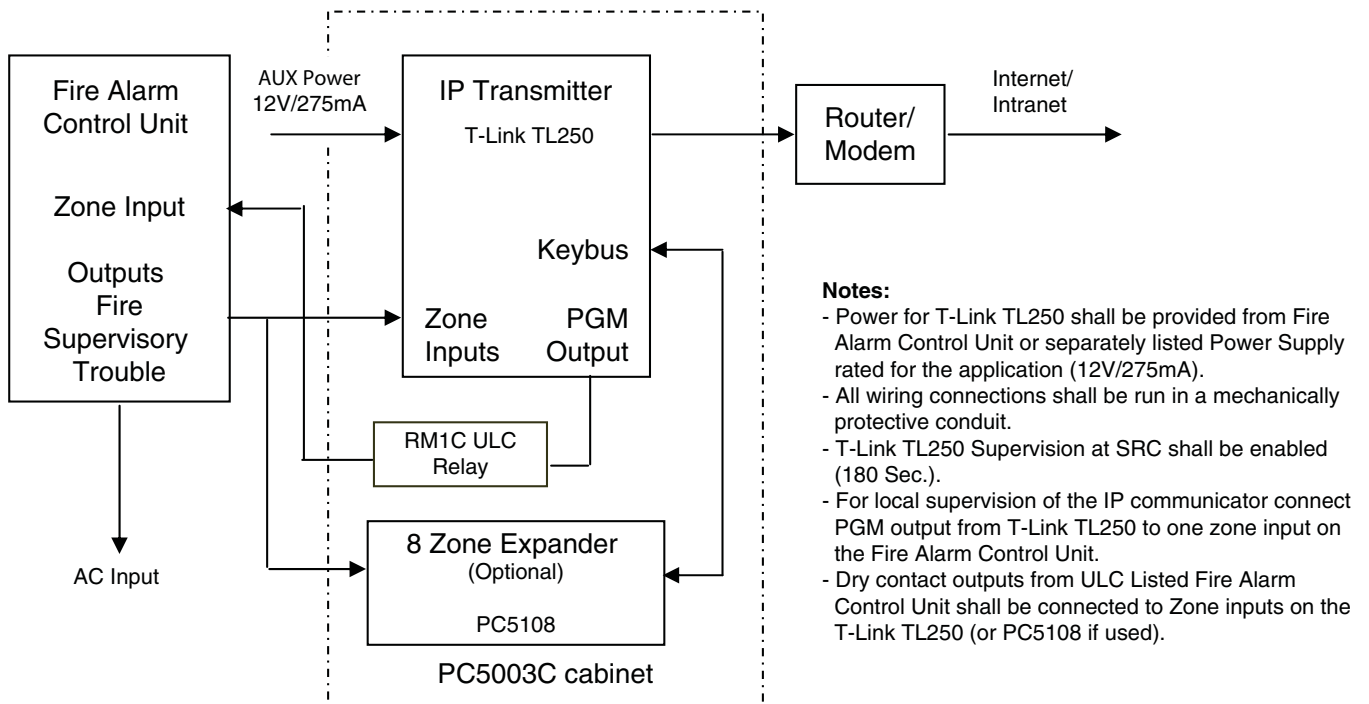

5. Fire Alarm Control Unit (with dialer) and IP Transmitter (Active Communication System)

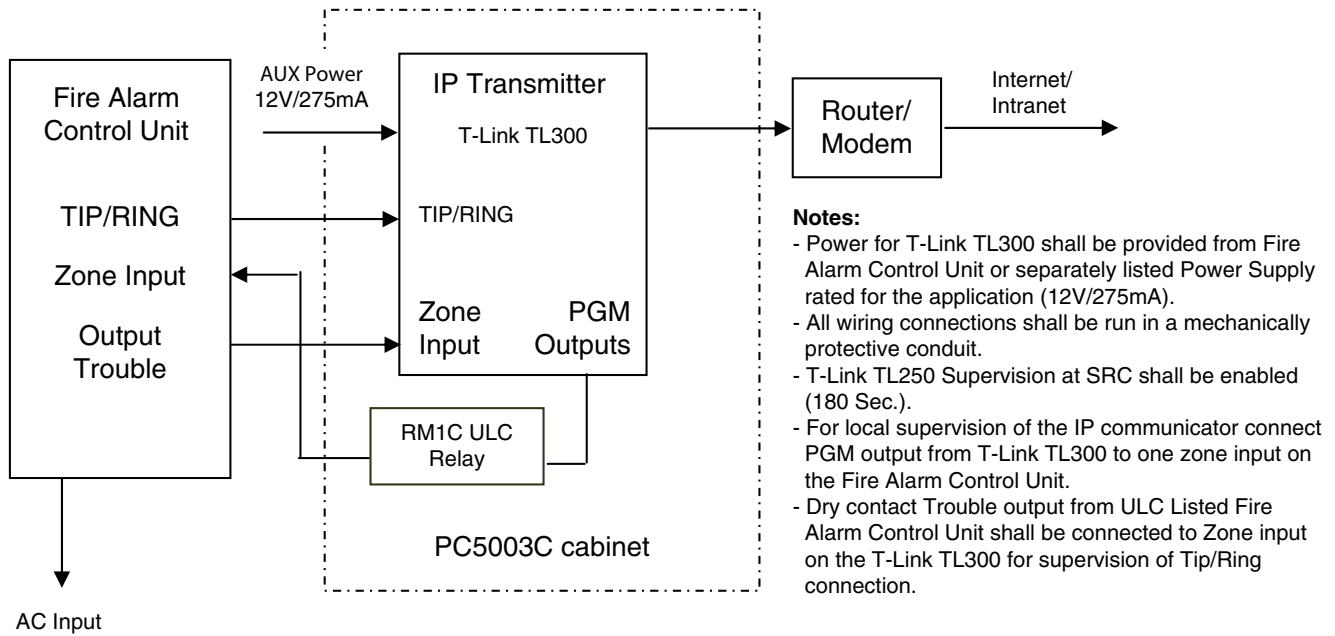

6. Fire Alarm Control Unit (with dialer) and GSM Transmitter (Passive Communication System)

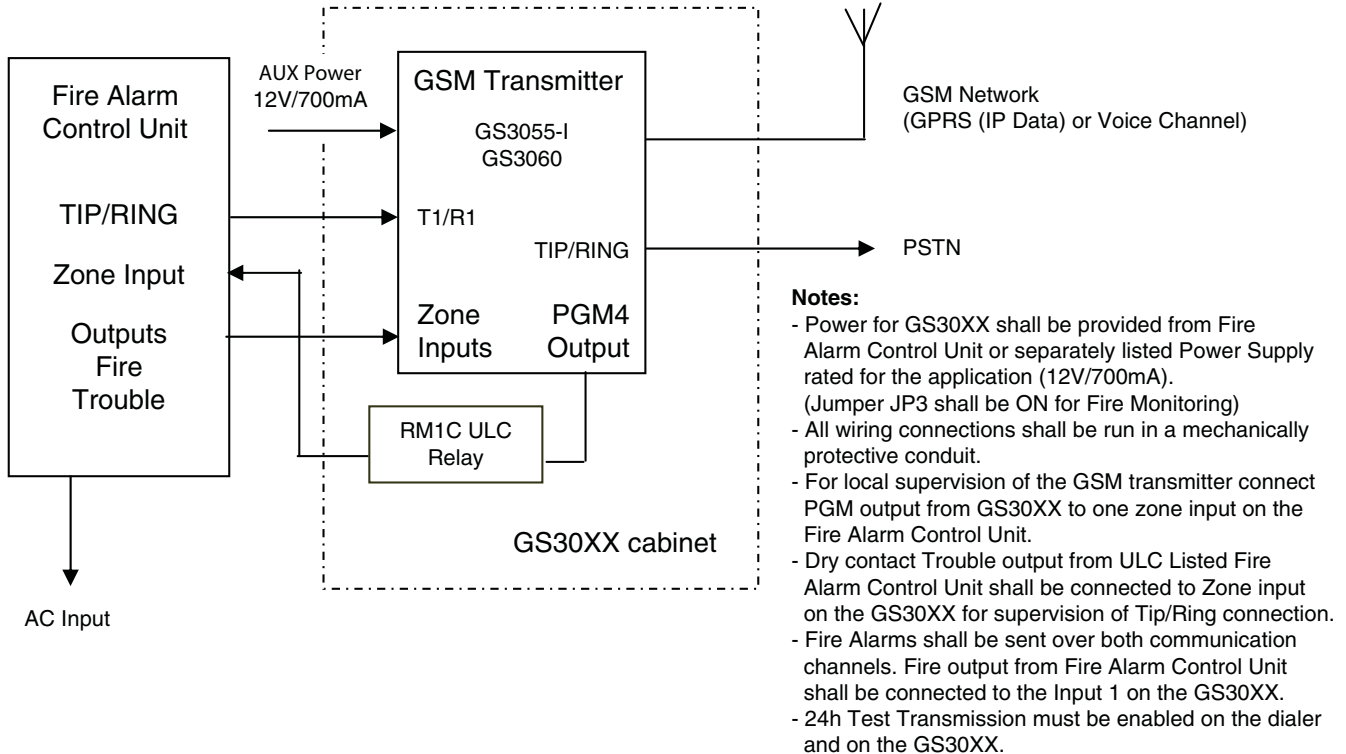

7. DSC Subscribers' Unit Fire and GSM Transmitter (Passive Communication System)

